

Block Diagram of Baseband (Version: 1.2 V: 3.0 E: 122)

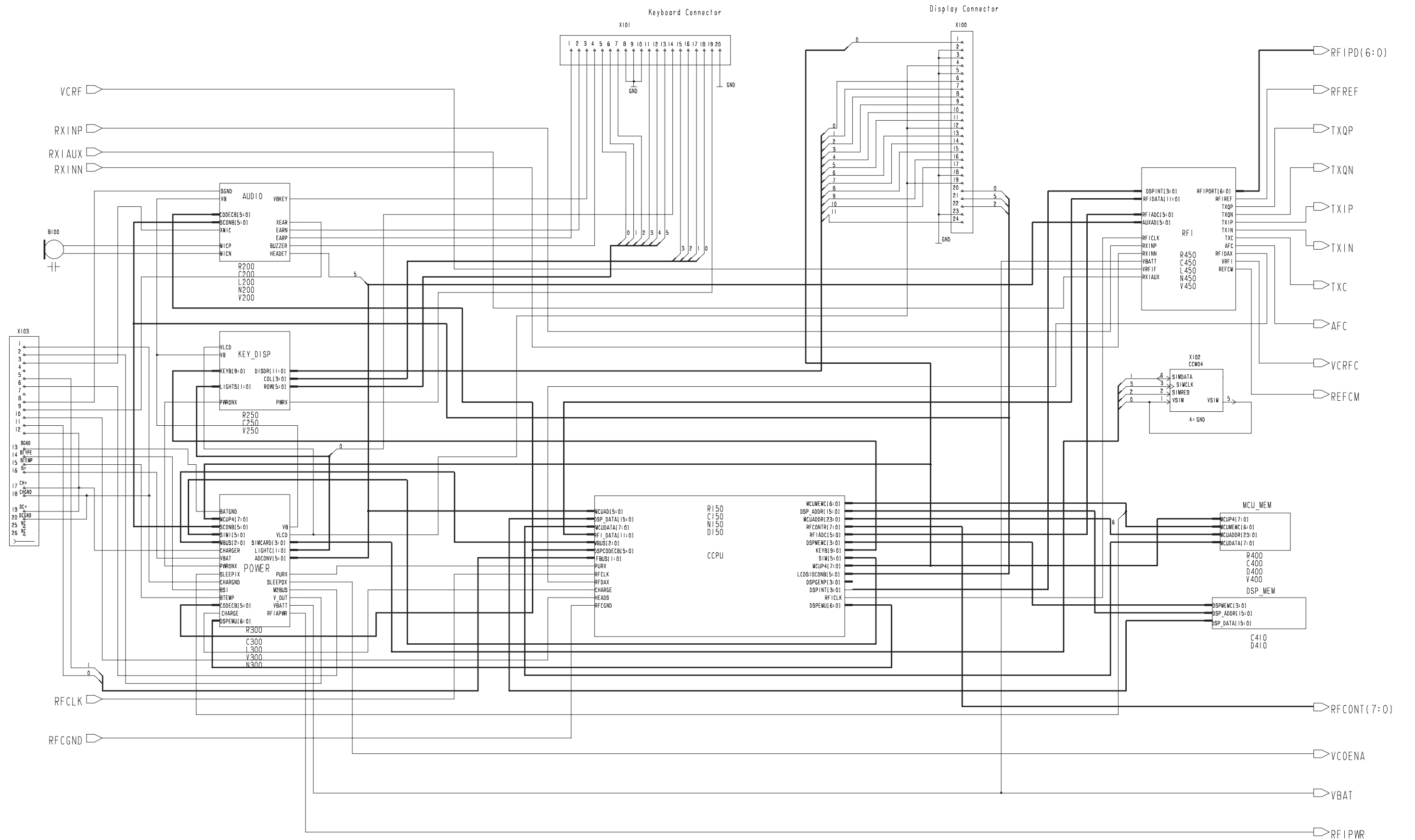

Circuit Diagram of Power Supply & Charging (Version 3.0 ; Edit 178)

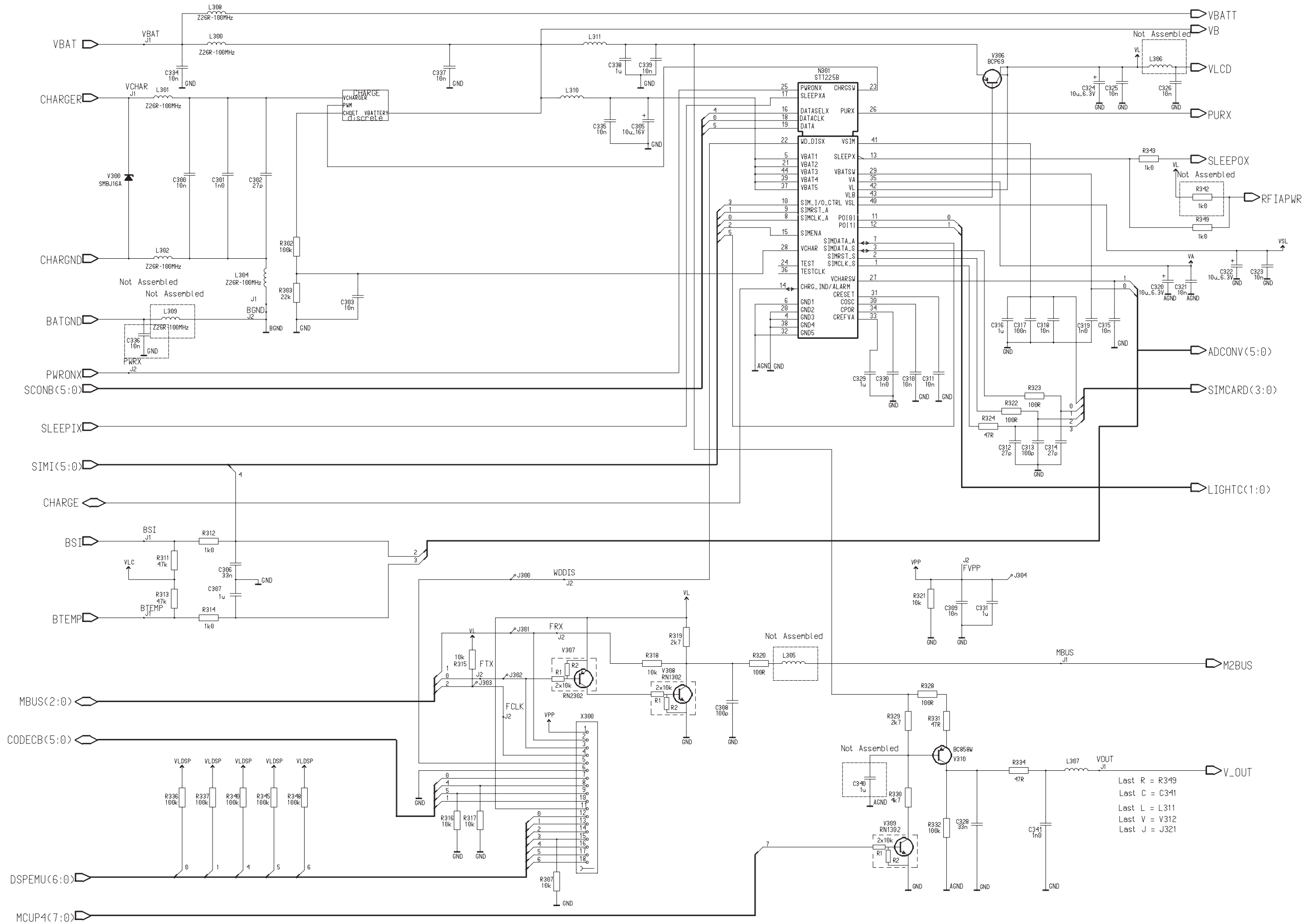

Circuit Diagram of Central Processing Unit (Version: 3.0 ; Edit 151)

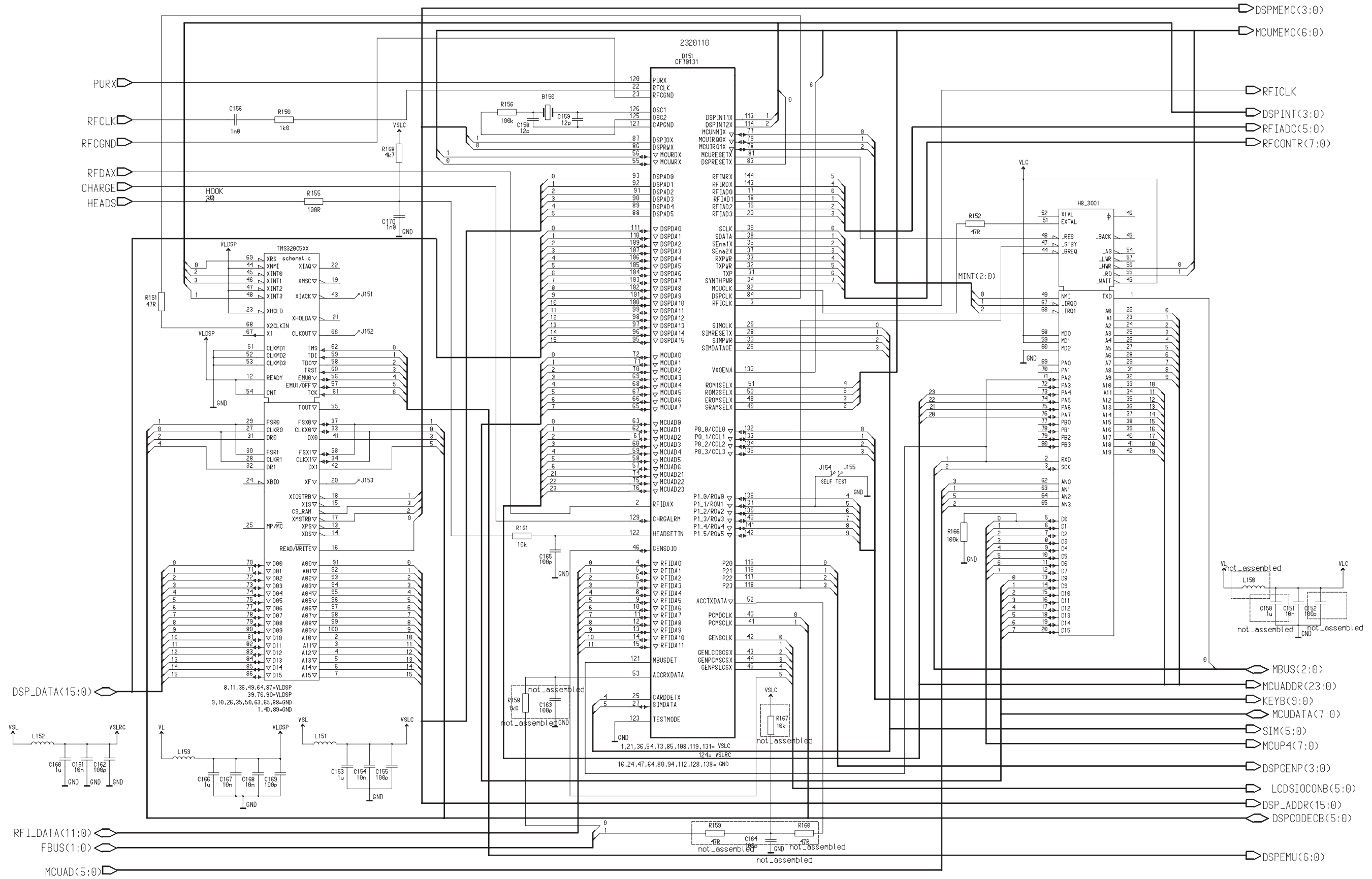

Last L = L153
 Last C = C170
 Last R = R170
 Last D = D152
 Last J = J155

Circuit Diagram of MCU Memory Block (Version: 3.0 ; Edit 87)

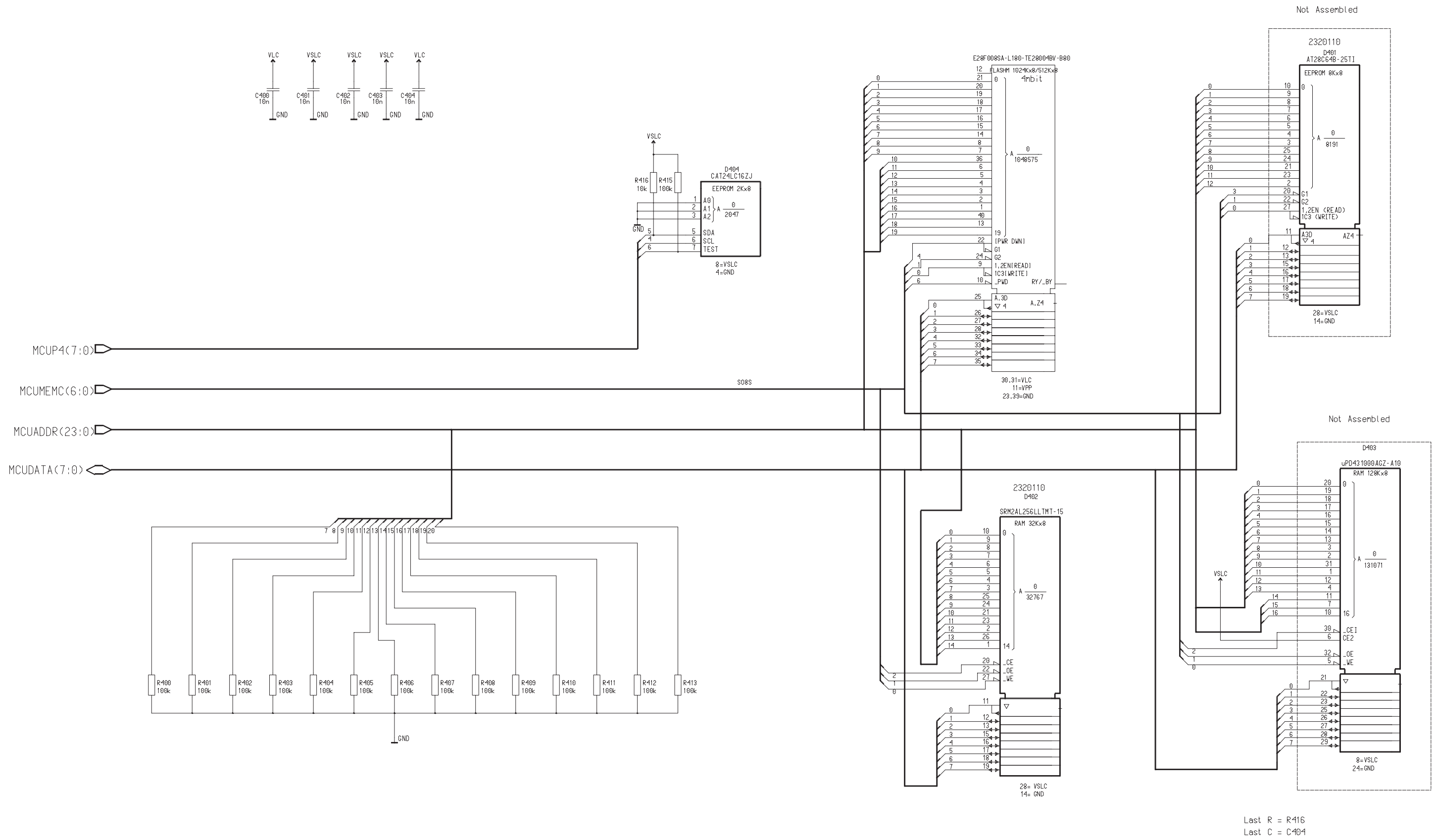

Last R = R416
 Last C = C404

Circuit Diagram of Keyboard & Display Interface (Version: 3.0 ; Edit 72)

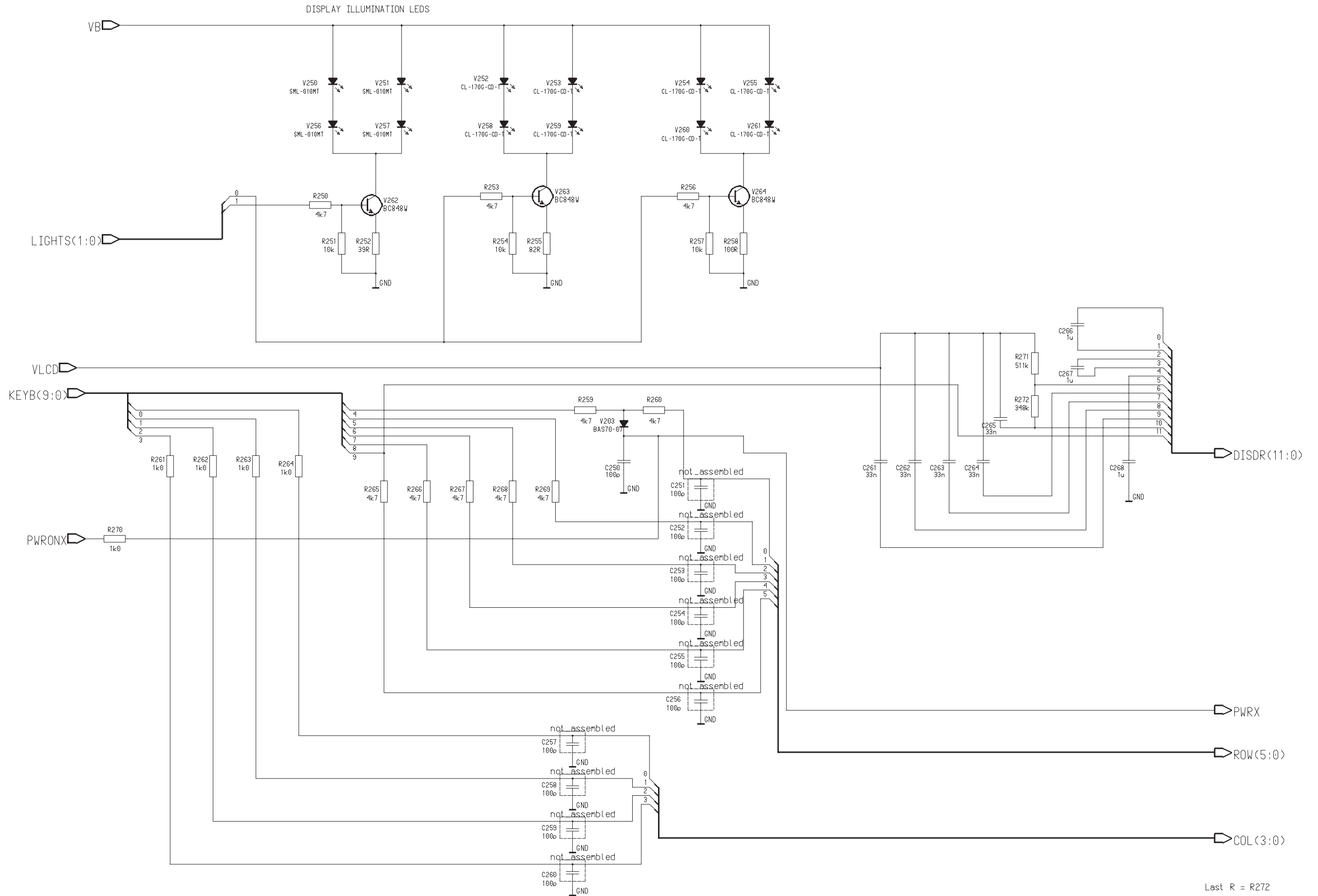

Last R = R272
 Last C = C268
 Last V = V264

Circuit Diagram of Audio (Version: 3.4 ; Edit 116)

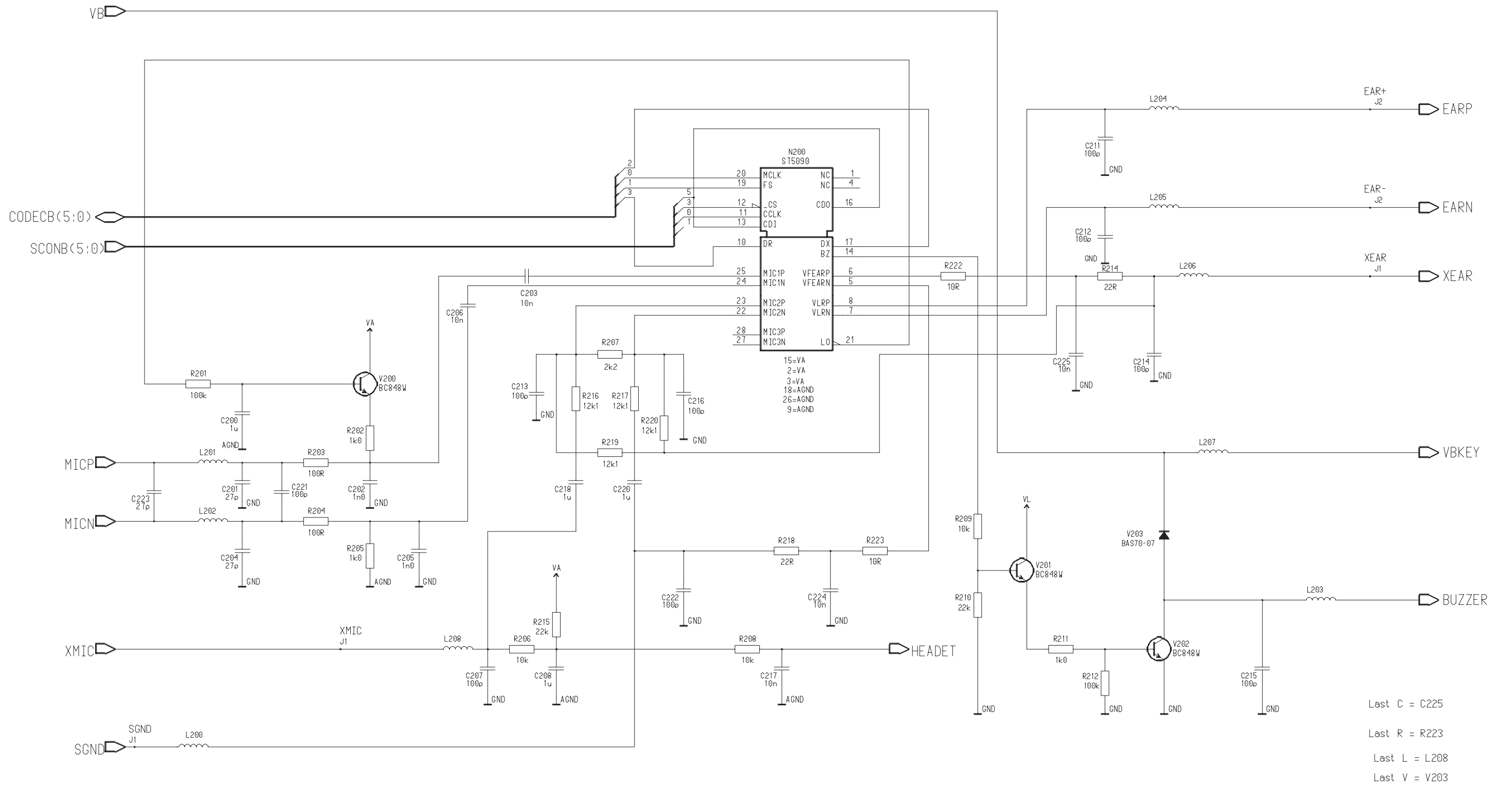

Circuit Diagram of DSP Memory Block (Version: 3.0 ; Edit 53)

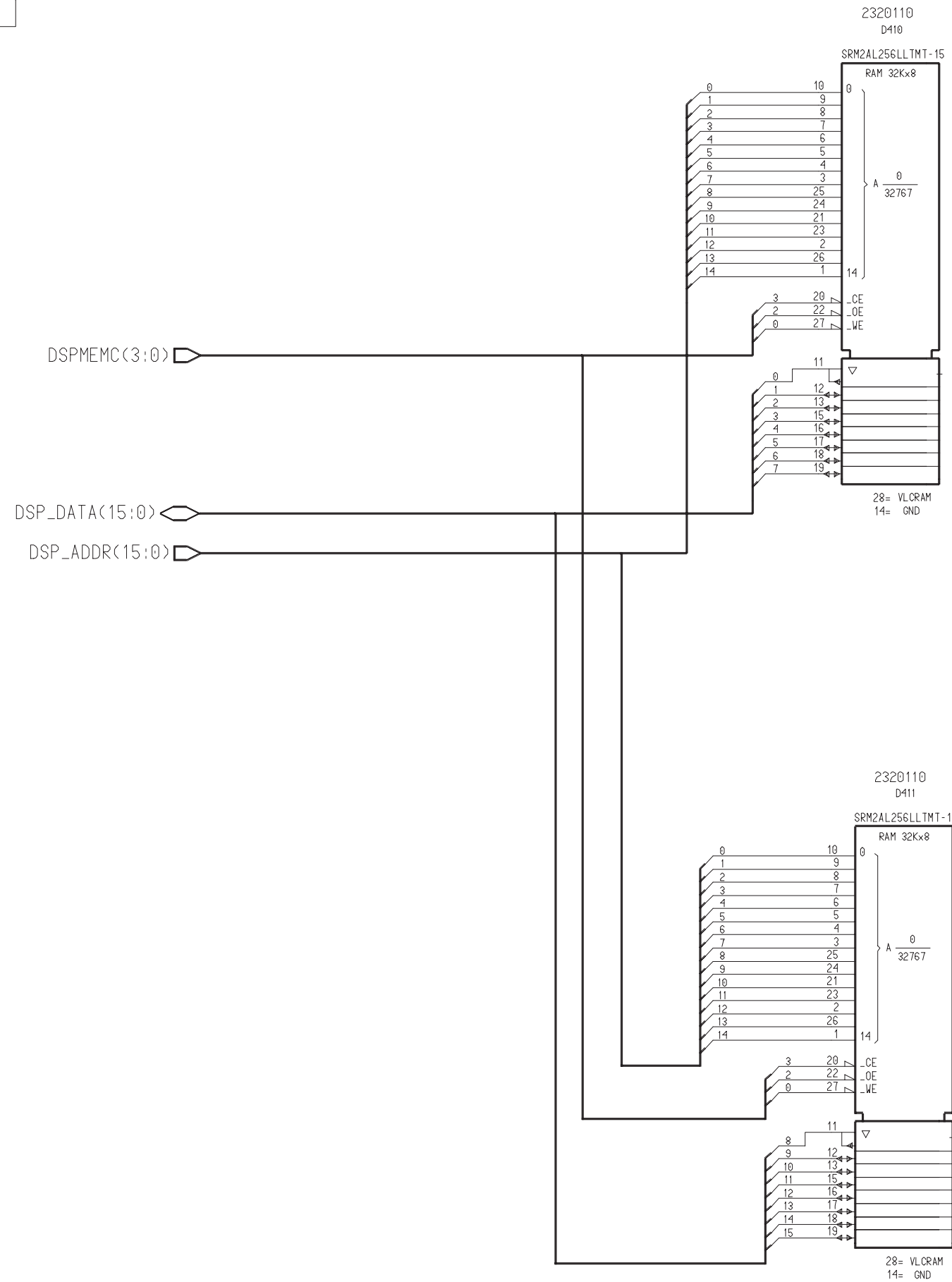
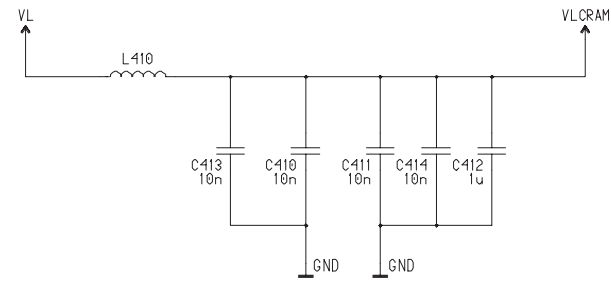

Circuit Diagram of RFI (Version: 3.0 ; Edit 76)

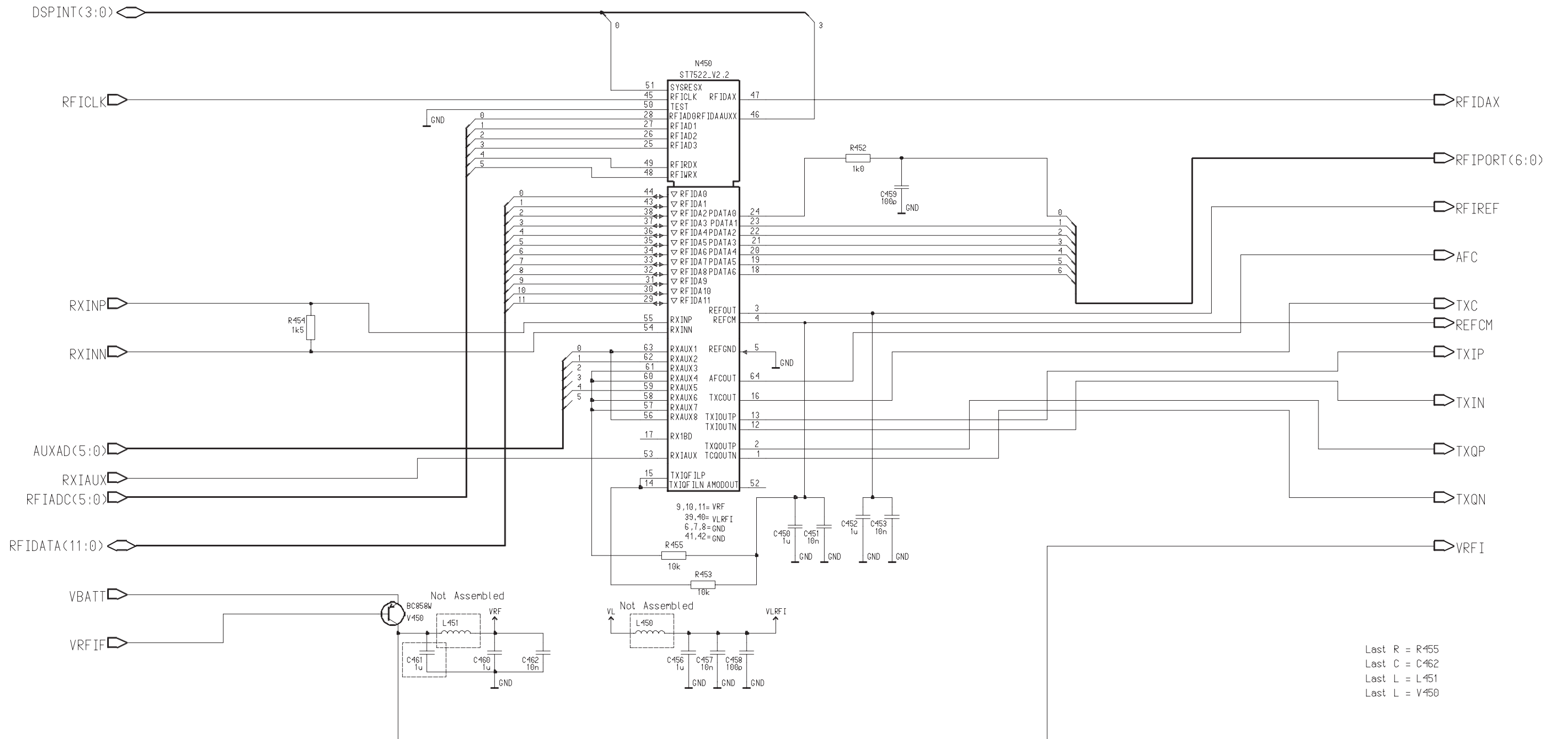

Circuit Diagram of Receiver (Version: 3.8 ; Edit 205)

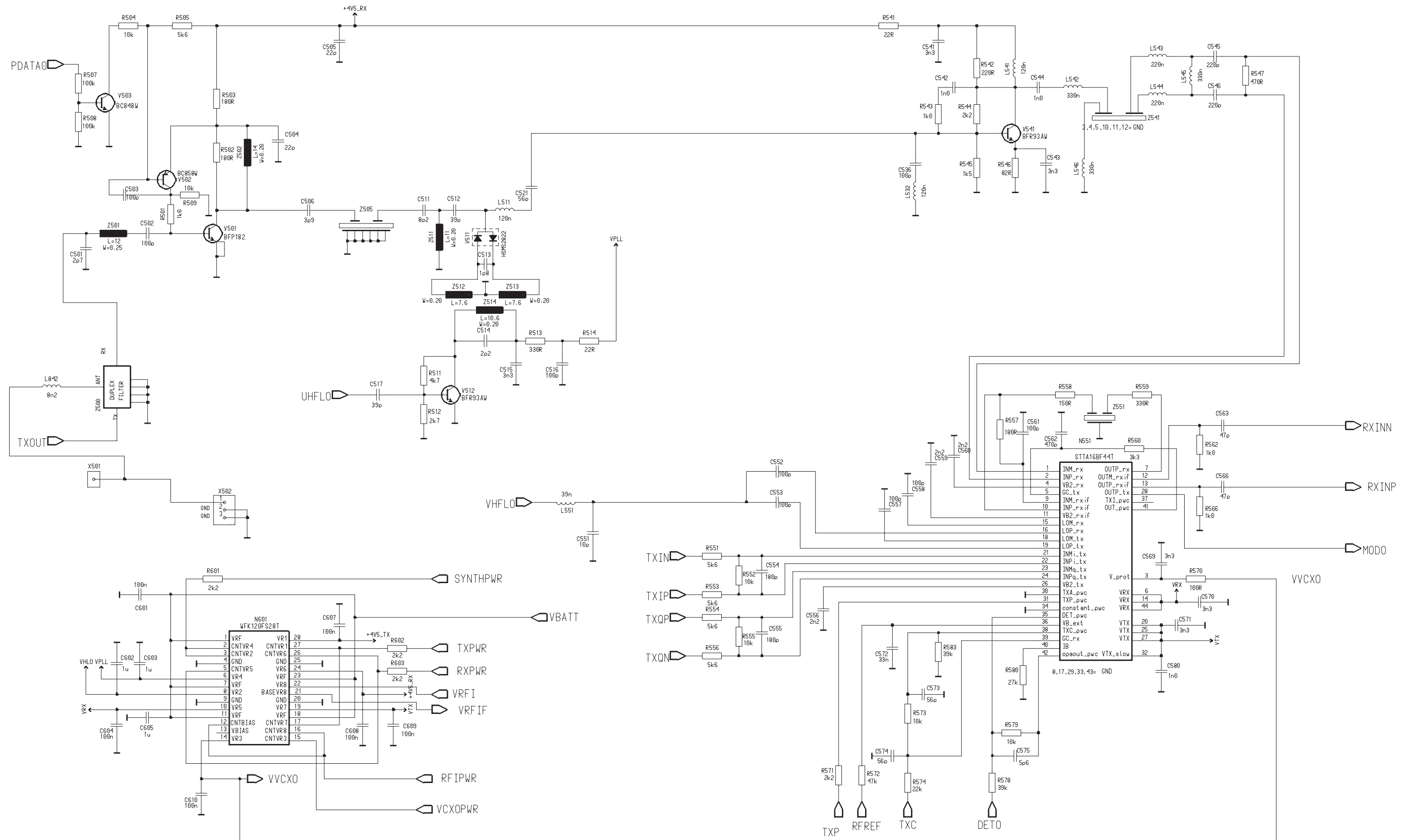

Circuit Diagram of Transceiver (Version: 3.8 ; Edit 235)

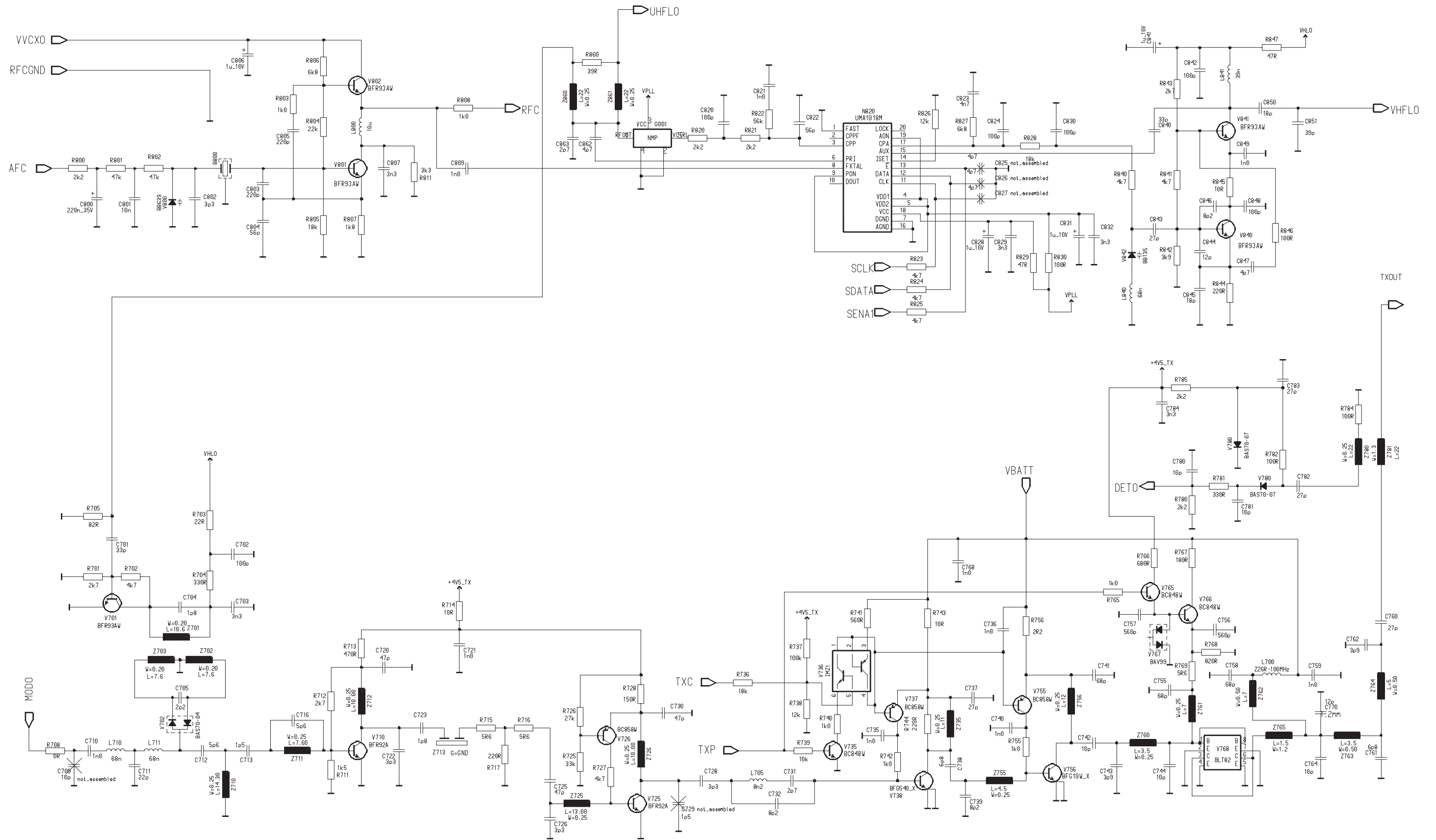

Layout Diagrams of GT8 (Version: 18)



